

0.1 Watt & 1 Watt

- Precision Voltage Regulated
- Output Voltages up to 100V
- Low Ripple, <10mV
- TTL-compatible Disable Pin
- Ultra-thin Package
- Epoxy coated
- Operating Temperature -20°C to +70°C
- 3 Year Warranty

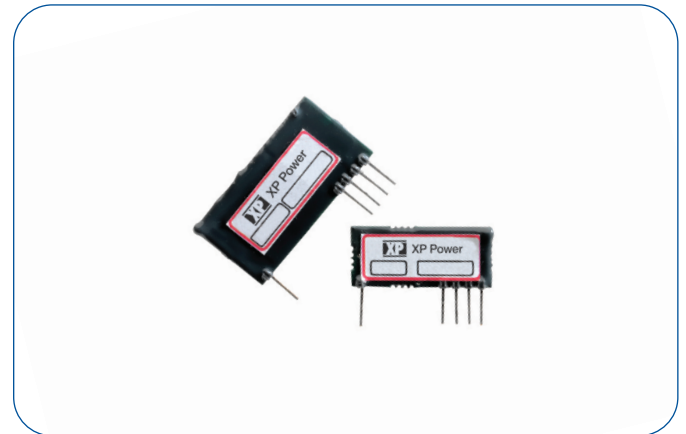

The SIP Series provides high performance in an ultra-thin, miniature single in-line package. Designed for low cost, high quantity applications, these DC to DC converters deliver high stability with very low ripple. The output voltage is programmable via a 0 to 5 volt analog voltage. The output voltage is inversely proportional to the programming voltage. Applying 5 volts to the programming input sets the output voltage to the minimum level. Conversely, 0 volts on the programming input sets the output voltage to the maximum level.

The units are linearly programmable throughout the output range. An enable/disable function is included; applying a TTL Low (open collector compatible) disables the output voltage to less than 10 volts. The SIP Series is a low cost, low power solution ideal for Photomultiplier tubes and APD biasing.

Dimensions:

SIP90: 1.15 x 0.55 x 0.16" (29.2 x 14.0 x 4.1mm)
 SIP100: 1.45 x 0.75 x 0.16" (36.8 x 19.1 x 4.1mm)

Key Applications:

- Photomultiplier Tubes
- Mass Spectrometers
- Avalanche Photodiodes
- Microchannel Plates
- Capacitor Charging

Models & Ratings

Characteristic	Minimum	Typical	Maximum	Units	Notes & Conditions
SIP90					
Output Voltage	25		90	VDC	
Output Current			1	mA	
Ripple and Noise			5	mV	
Line Regulation					
Load Regulation			0.03	%	
Input Voltage	3		6.7	VDC	
Input Current, No Load			125	mA	
Input Current, Full Load			150	mA	
SIP100					
Output Voltage	25		100	VDC	
Output Current			10	mA	
Ripple and Noise			10	mV	at Max Vout, Full Load
Line Regulation			0.2	%	
Load Regulation			0.1	%	
Input Voltage	4		6.7	VDC	
Input Current, No Load			75	mA	
Input Current, Full Load			350	mA	

General Specifications

Characteristic	Minimum	Typical	Maximum	Units	Notes & Conditions
All Models					
Minimum Load	No minimum load required				
Programming Voltage Input, VPGM	0		5	VDC	See page 2 for details
Disable input					TTL Low to disable
Temperature Coefficient			100	ppm/°C	
Stability			100	ppm/hr	
Isolation	N/A - Input ground is connected to output ground				
Construction	Epoxy coated				
Switching Frequency	1.8	2	2.2	MHz	
MTBF	2.03			Mhrs	
Operating Temperature	-20		70	°C	
Storage Temperature	-20		105	°C	

Block Diagram

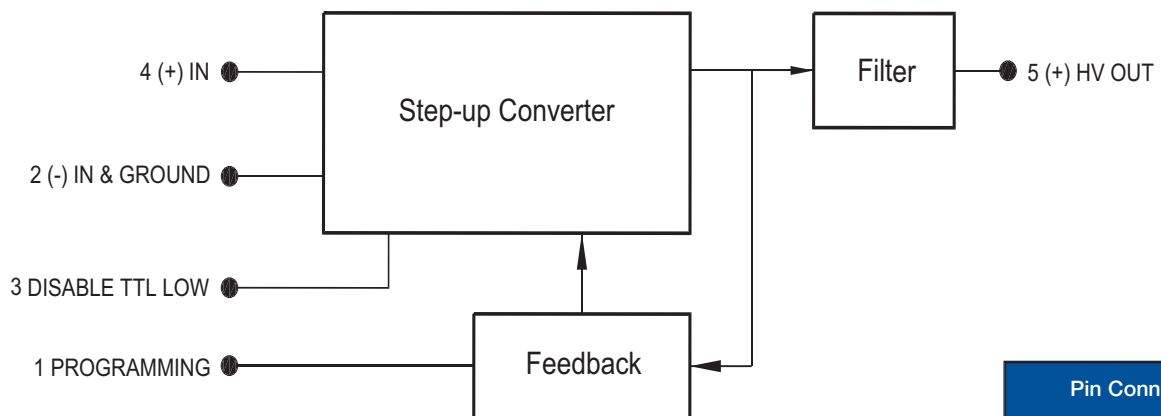

Pin Connections	
Pin	Function
1	VPGM
2	GROUND
3	DISABLE
4	VIN
5	HV OUT

Mechanical Details

SIP90

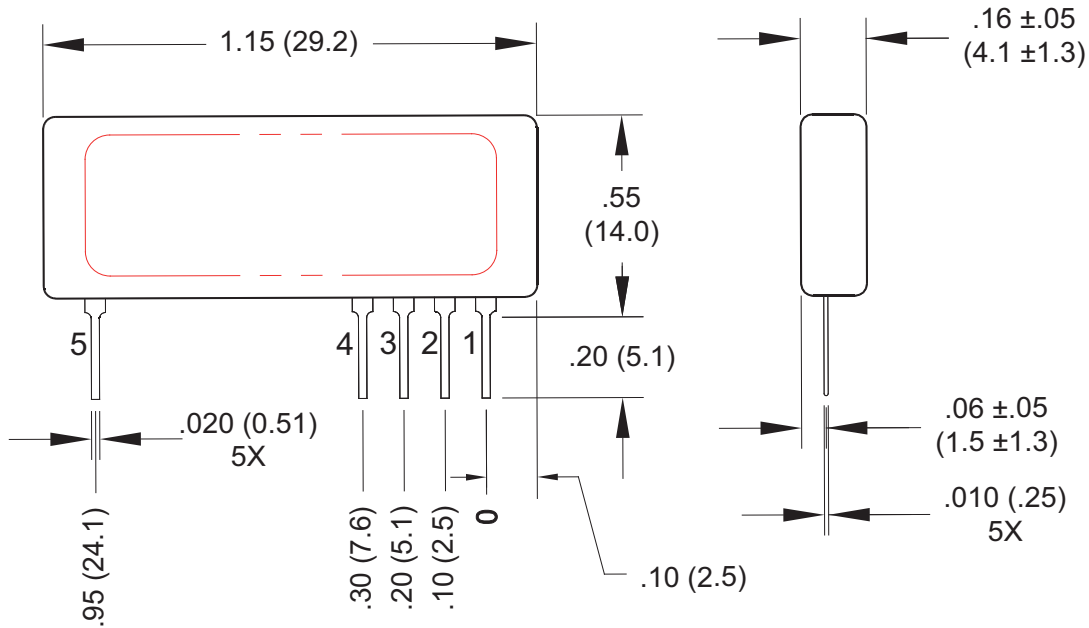

SIP100

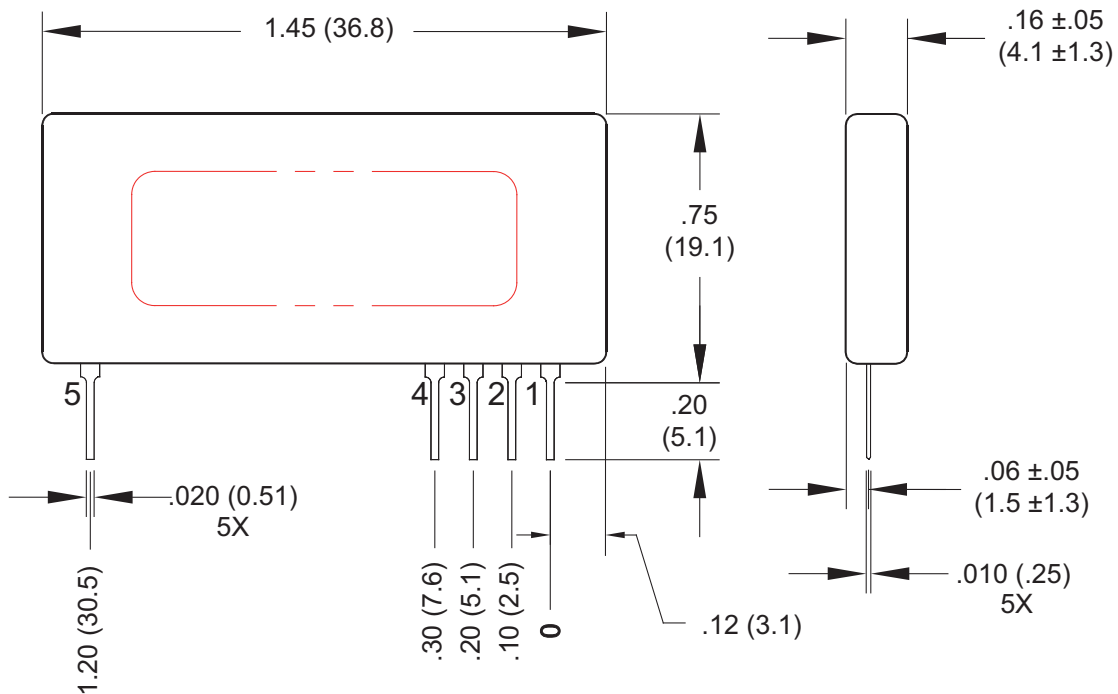

Notes

1. All dimensions are in inches (mm)
2. Weight: SIP90, 0.2oz (5g)
SIP100, 0.25oz (7.1g)

3. Tolerance: X.XX±0.02 (0.51)
4. Pin Tolerance: ±0.005 (0.127)

Distribution:

hivolt.de

hivolt.de GmbH & Co. KG
 Oehleckerring 40 • D-22419 Hamburg • Germany
 +49 40 537122-0
 info@hivolt.de • www.hivolt.de

Distribution:

hivolt.de

hivolt.de GmbH & Co. KG
Oehleckerring 40 • D-22419 Hamburg • Germany
+49 40 537122-0
info@hivolt.de • www.hivolt.de