

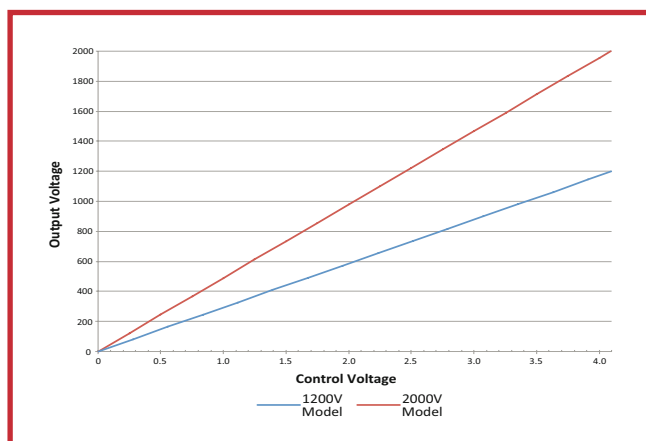

PRODUCT DESCRIPTION

The P Series of micro-power DC to high voltage DC converters feature extremely low ripple (<100µV) and low EMI/RFI due to a unique magnetic-free design. Very low power consumption and light weight, with a case height of less than 0.220 inches, make these PC mount modules ideal for portable, battery powered equipment.

Fully regulated and programmable outputs of 0 to 1200 volts or 0 to 2000 volts are available in positive or negative polarity. A precision on-board reference and high impedance voltage programming input allow for easy plug-and-play designs. An output voltage monitor is standard. Soft-start high voltage ramp-rates protect sensitive detectors to support long term reliability.



PRODUCT SELECTION TABLE

MODEL	OUTPUT VOLTAGE	OUTPUT CURRENT ¹
P12P	0 to + 1200V	2 µA
P12N	0 to - 1200V	2 µA
P20P	0 to + 2000V	1 µA
P20N	0 to - 2000V	1 µA

FEATURES

- Ultra-low Noise Magnetic-free Design
- Regulated
- Miniature Size
- Grounded Metal Case
- 0 to 100% Programmable Output
- Wide Input Voltage Range, 5 to 12 VDC
- Ultra Low Ripple < 100µV
- Ultra-low EMI/RFI
- Voltage Monitor
- External Voltage or Potentiometer Programming
- Low Power Consumption
- Built-in Voltage Reference
- Soft-Start
- High Reliability: MTBF >1.6 Million Hours per Bellcore TR-332
- RoHS Compliant

APPLICATIONS

- Portable, Battery Powered CBRN Detectors
- Low Power Electrostatic Applications
- Low Power Biasing
- Low Power Piezo Devices
- Low Power Aerosol Devices

OPTIONS

- Polarity: Choose Positive or Negative Output (P/N)
- Extended Operating Temperature (T Suffix)
- Other Output Voltages Available (Consult Factory)
- See Ordering Information (Page 5)



ELECTRICAL SPECIFICATIONS

PARAMETER	VALUE
INPUT VOLTAGE	5 VDC to 12 VDC
INPUT CURRENT ⁷	1200 V Models: < 2.1mA No Load < 3.3mA Full Load
	2000 V Models: < 2.6mA No Load < 3.6mA Full Load
INPUT CAPACITANCE	~1.0 μ F
RESPONSE TIME ⁵	900ms (Typical)
TURN-ON TIME ⁶	1200V Models: 10s (Typical)
	2000V Models: 15s (Typical)
OUTPUT VOLTAGE TOLERANCE	1200V Models: +/-1% at full scale
	2000V Models: +/-1% at full scale
OPERATING TEMPERATURE	-10° to 70°C Standard (Case)
	-55° to 85°C Extended (Case)
STORAGE TEMPERATURE	-55° to 105°C
RIPPLE	< 100 μ V peak to peak at full output
STANDBY CURRENT (0 OUTPUT VOLTAGE)	< 300 μ A
TEMPCO	+/-250 ppm/°C (Typical) ⁸
FREQUENCY	24kHz +/-10%

DETAILED PRODUCT DESCRIPTION

The P Series of micro-power DC to HV DC converters offers a programmable 0 to 1200 V or 0 to 2000 V DC output in a miniature, lightweight, PC mount package. Positive and negative outputs are available. The output voltage is linear to the programming voltage, from turn on to maximum output voltage, enabling easy low voltage control of the high voltage. A precision on-board voltage reference allows for simple configuration for full scale, fixed or variable output. Voltage monitoring is provided at a 1000:1 ratio.

Ripple voltage less than 100 microvolts and extremely low EMI/RFI make this product ideal for integration into noise sensitive equipment. The P Series features a unique inductor/transformer-less design, grounded case and draws less than 4mA at full output.

The new P Series leverages EMCO's Best-in-Class long term reliability, utilizing proven DC to high voltage DC conversion technology, perfected by over four decades of high voltage design and experience in the most demanding applications. Our extensive in house capabilities enable us to meet specific customer requirements with standard, modified and custom solutions quickly, easily and economically. Technical assistance is readily available

MECHANICAL SPECIFICATIONS

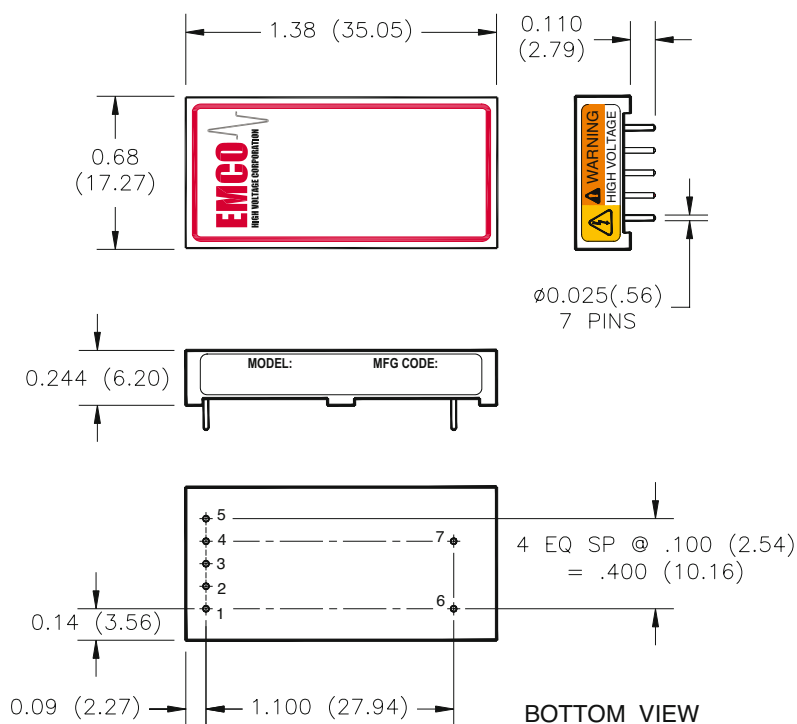

DIMENSIONS ARE IN INCHES (METRIC EQUIVALENTS ARE IN PARENTHESIS)
 DIMENSIONAL TOLERANCES: .XX = ± 0.02 (0.51), .XXX = ± 0.005 (0.127)

PARAMETER	VALUE
WEIGHT	0.26 OZ (7.5 Grams)
VOLUME	0.24 cu. In. (3.9 cc)
DIMENSIONS	1.38L (35.05L) x 0.68W (17.27W) x 0.244 (6.20H)

PIN	FUNCTION
1	GROUND ²
2	VIN
3	REF
4	CONTROL
5	MONITOR
6	GND ⁴ (HV RTN)
7	HV OUT

TYPICAL APPLICATIONS

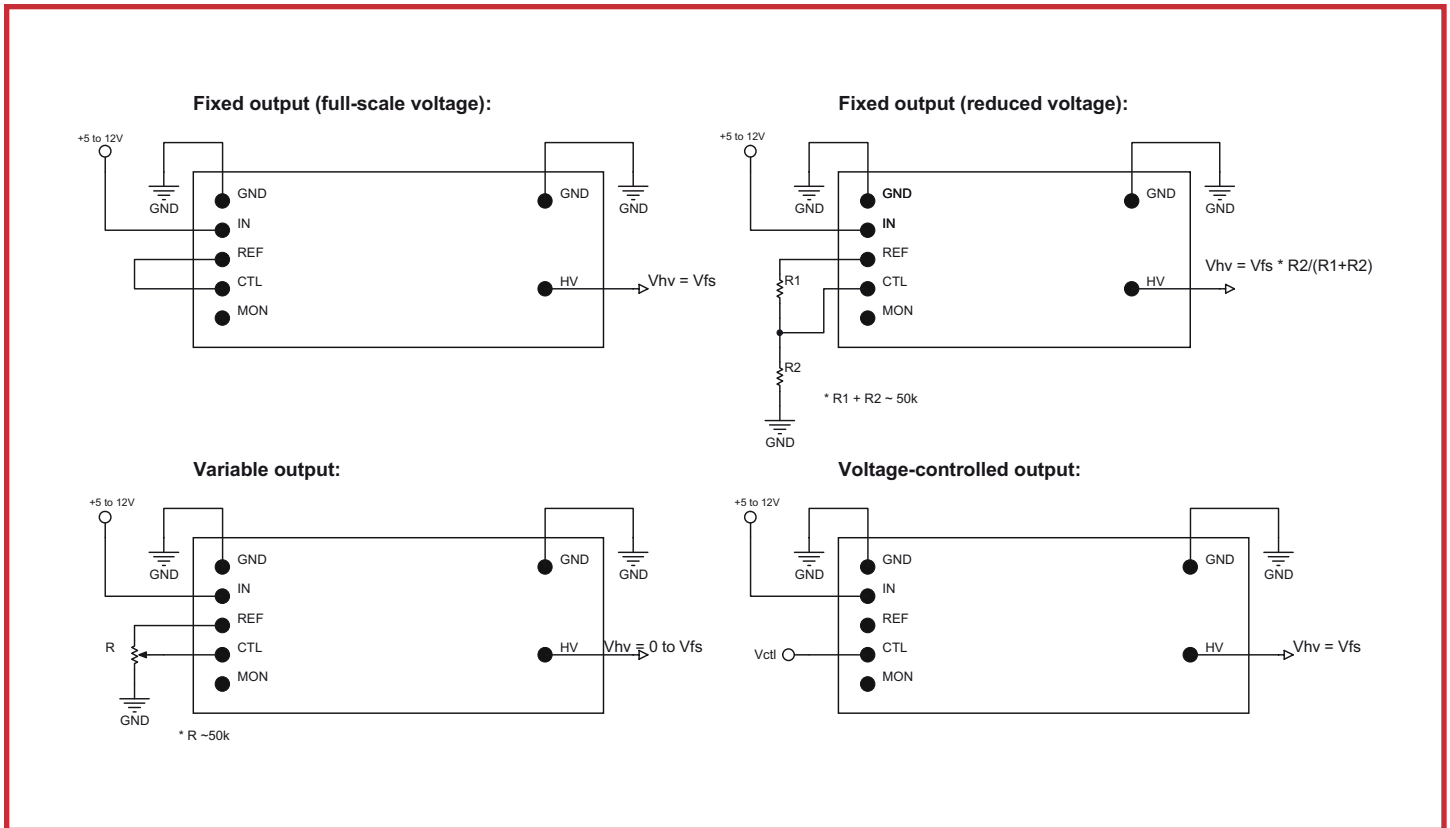

PIN	FUNCTION
GND	Ground ^{1,2} (Connected to Case)
IN	Input (+5 to 12V)
REF	Reference Voltage ⁴ (+4.096V)
CTL	Control Voltage Input (V_{CTL}) 0 to 4.096V
MON	Voltage Monitor Output ⁴ (V_{MON}) = ($V_{HV} / 1000$)
HV	High Voltage Output (V_{HV}) = $V_{FS} * V_{CTL} / 4.096$

BLOCK DIAGRAM

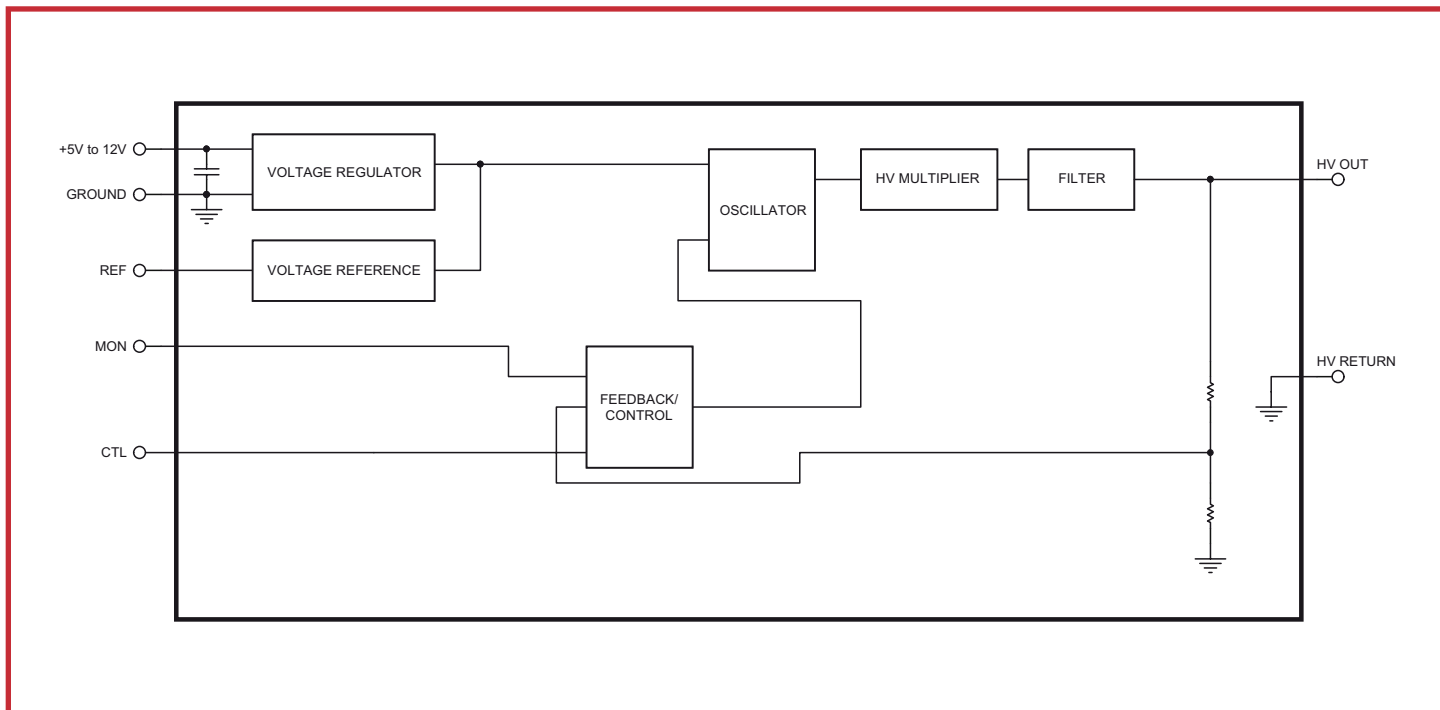

HOW TO ORDER

PART NUMBER SELECTOR:

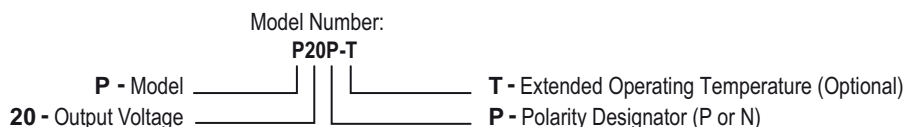

EXAMPLE: **P20P-T** (P Model, 2,000-Output Voltage, P-positive, T-Extended Operating Temperature)

- Note:
1. At maximum rated output voltage.
 2. All grounds are internally connected to case. Grounded case assists low noise design efforts. Both ground pins must be connected to ground for proper operation.
 3. Full scale voltage is maximum output voltage.
 4. Reference and monitor should be left floating when not in use to reduce power consumption.
 5. Time to respond to change in control voltage when Startup Time has elapsed.
 6. Time to output high voltage from initial power to device.
 7. With nominal supply voltage = 5 V.
 8. Using internal voltage reference tied to control pin.

XP-EMCO reserves the right to make changes on products and literature, including specifications, without notice. XP-EMCO standard product models are not recommended for "copy-exact" applications or any other application restricting product changes. "Copy-exact" options are available. Please contact an XP-EMCO sales representative for more details.