

**Proven
Reliability**

G SERIES

ISOLATED, PROPORTIONAL DC TO HV DC CONVERTERS

100V to 6kV at 1.5W



PRODUCT DESCRIPTION

The G Series is a line of miniature, versatile component level building blocks that provide up to 6kV, positive or negative, in a compact PC mount package. The isolated output is directly proportional to the input, and is linear from approximately 0.7 volts in. Excellent filtering techniques and a low noise quasi-sinewave oscillator provide clean, reliable DC to HV DC conversion with low ripple and low EMI/RFI. The isolated output allows for user selectable output polarity. An output center-tap option which, when grounded provides both positive and negative outputs from one compact, low cost module. The pin pattern on the G Series allows for a direct drop-in replacement for many larger high voltage modules. The GPMT model has been specifically designed for biasing PMT's.

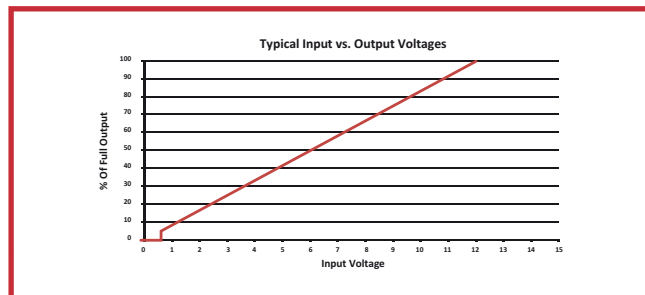

APPLICATIONS

- Capacitor Charging
- Piezo Devices
- Mass Spectrometry
- Electrostatic Chuck
- Igniter / Spark Module
- Sustaining Ion Pumps
- Piezo Devices
- Vacuum Gauges
- Photomultiplier Tubes
- Lamp Ignition and Drive

OPTIONS

- Center Tap Models Available (CT Suffix)
- External Mounting Enclosure (AB Suffix)
- Alternate Input/Output Combinations (Consult Factory)

PRODUCT SELECTION TABLE

MODEL	OUTPUT VOLTAGE*2	OUTPUT CURRENT*1
G01	100V	15mA
G02	200V	7.5mA
G03	300V	5mA
G04	400V	3.75mA
G05	500V	3mA
G06	600V	2.5mA
G10	1kV	1.5mA
G12	1.2kV	1.25mA
G15	1.5kV	1.0mA
G20	2kV	0.75mA
G25	2.5kV	0.60mA
G30	3kV	0.50mA
G40 ¹⁸	4kV	0.37mA
G50 ¹⁸	5kV	0.30mA
G60 ¹⁸	6kV	0.25mA
GPMT ⁷	1.25kV	350uA

FEATURES

- Proportional Input/Output
- Compact, PCB Mount Package
- Low Ripple, Low EMI / RFI
- Proven Reliability
- Short Circuit Protection
- Input/Output Isolation
- Low Leakage Current
- Low Input/Output Coupling Capacitance
- No External Components Required
- No Minimum Load Required
- MTBF: >2.29 Million Hours per Bellcore TR-332
- RoHS Compliant

ISO 9001:2008
CERTIFIED

ISO 14001:2004
CERTIFIED

RoHS
COMPLIANT

IPC
Certified J-STD-001
Application Specialist



Distribution:

hivolt.de

hivolt.de GmbH & Co. KG
Oehleckerring 40 • D-22419 Hamburg • Germany
+49 40 537122-0
info@hivolt.de • www.hivolt.de

4726BH

PAGE 1

ELECTRICAL SPECIFICATIONS^{*3}

REVERSIBLE MODEL	OUTPUT VOLTAGE ²	CENTER TAP MODEL ⁴	OUTPUT VOLTAGE ²	OUTPUT CURRENT ¹	INPUT CURRENT (NO LOAD)	INPUT CURRENT (FULL LOAD)	RIPPLE ⁵
G01	0 to 100V	G01CT	0 to +/- 50V	15mA	<100mA	<250mA	<1.75%
G02	0 to 200V	G02CT	0 to +/- 100V	7.5mA	<100mA	<250mA	<0.75%
G03	0 to 300V	G03CT	0 to +/- 150V	5mA	<100mA	<250mA	<0.75%
G04	0 to 400V	G04CT	0 to +/- 200V	3.75mA	<100mA	<250mA	<0.75%
G05	0 to 500V	G05CT	0 to +/- 250V	3mA	<100mA	<250mA	<0.1%
G06	0 to 600V	G06CT	0 to +/- 300V	2.5mA	<100mA	<250mA	<0.1%
G10	0 to 1kV	G10CT	0 to +/- 500V	1.5mA	<100mA	<250mA	<0.1%
G12	0 to 1.2kV	G12CT	0 to +/- 600V	1.25mA	<150mA	<275mA	<0.1%
G15	0 to 1.5kV	G15CT	0 to +/- 750V	1.0mA	<125mA	<275mA	<0.5%
G20	0 to 2kV	G20CT	0 to +/- 1kV	0.75mA	<165mA	<275mA	<0.5%
G25	0 to 2.5kV	G25CT	0 to +/- 1.25kV	0.60mA	<125mA	<275mA	<1.0%
G30	0 to 3kV	G30CT	0 to +/- 1.5kV	0.50mA	<125mA	<300mA	<2.0%
G40	0 to 4kV	G40CT	0 to +/- 2kV	0.37mA	<125mA	<300mA	<1.0%
G50	0 to 5kV	G50CT	0 to +/- 2.5kV	0.30mA	<125mA	<300mA	<2.0%
G60	0 to 6kV	G60CT	0 to +/- 3kV	0.25mA	<125mA	<300mA	<2.0%
GPMT	0 to 1.25kV	—	—	350uA	<35mA	<75mA	<0.05%

ELECTRICAL SPECIFICATIONS^{*3}

PARAMETER	VALUE
INPUT VOLTAGE	0 to 12VDC
TURN-ON VOLTAGE	<0.7VDC
ISOLATION	< +/-3.5kV BIAS
INPUT CAPACITANCE	120 μ F
RESPONSE TIME	<15ms (G01 thru G60 Models)
	<40ms (GMPT Models)
OUTPUT VOLTAGE TOLERANCE	+/-3% (Full Load, 100% output voltage)
REGULATION	<10% VARIATION OVER LOAD RANGE
FREQUENCY	125kHz +/- 65kHz
OPERATING TEMPERATURE ⁶	-10C to +60°C (CASE)
STORAGE TEMPERATURE	-25C to +90°C

G01 THRU G40, GPMT MECHANICAL SPECIFICATIONS

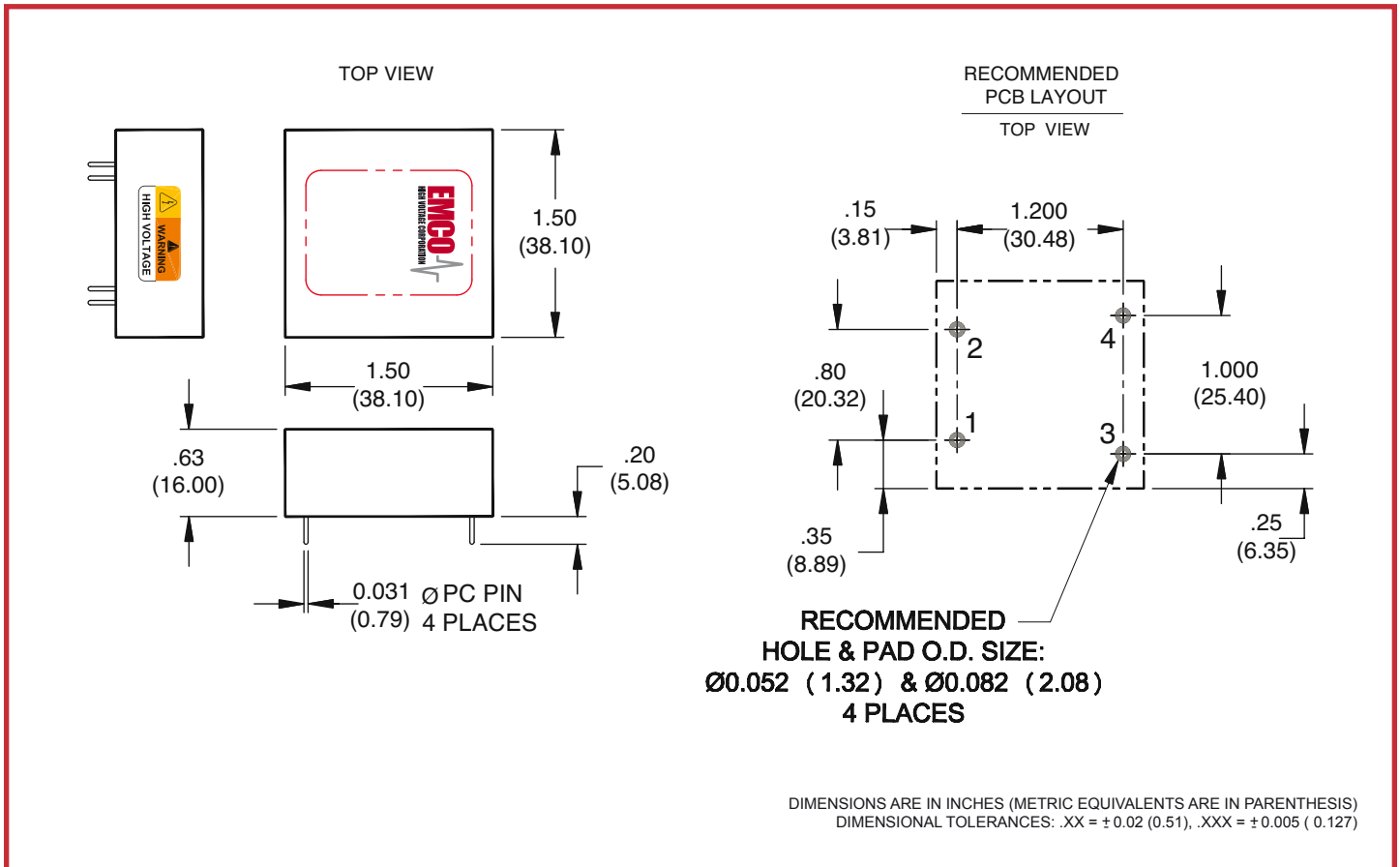

PARAMETER	VALUE
WEIGHT	Weight: 1.5 OZ (43 Grams)
VOLUME	1.4 cubic Inches (23 cubic centimeters)
DIMENSIONS	1.5L (38.1L) x 1.5W (38.1L) x 0.63H (16.0H)
CASE MATERIAL	Diallyl Phthalate (DAP)

PIN #	FUNCTION
1	(+) Input
2	(-) Input
3	(+) Output
4	(-) Output

G50 THRU G60 MECHANICAL SPECIFICATIONS

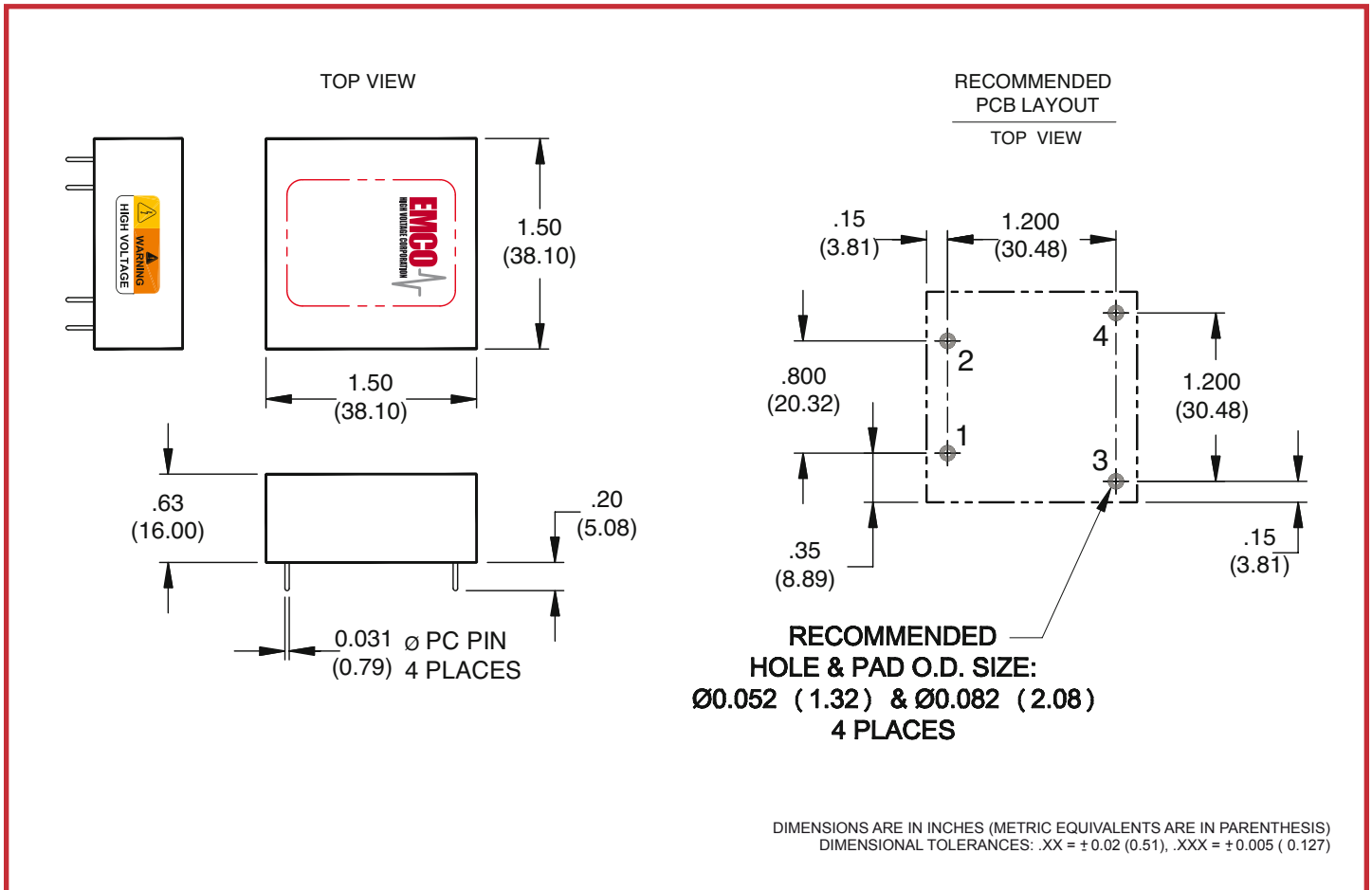

PARAMETER	VALUE
WEIGHT	Weight: 1.5 OZ (43 Grams)
VOLUME	1.4 cubic Inches (23 cubic centimeters)
DIMENSIONS	1.5L (38.1L) x 1.5W (38.1L) x 0.63H (16.0H)
CASE MATERIAL	Diallyl Phthalate (DAP)

PIN #	FUNCTION
1	(+) Input
2	(-) Input
3	(+) Output
4	(-) Output

G01CT THRU G20CT MECHANICAL SPECIFICATIONS

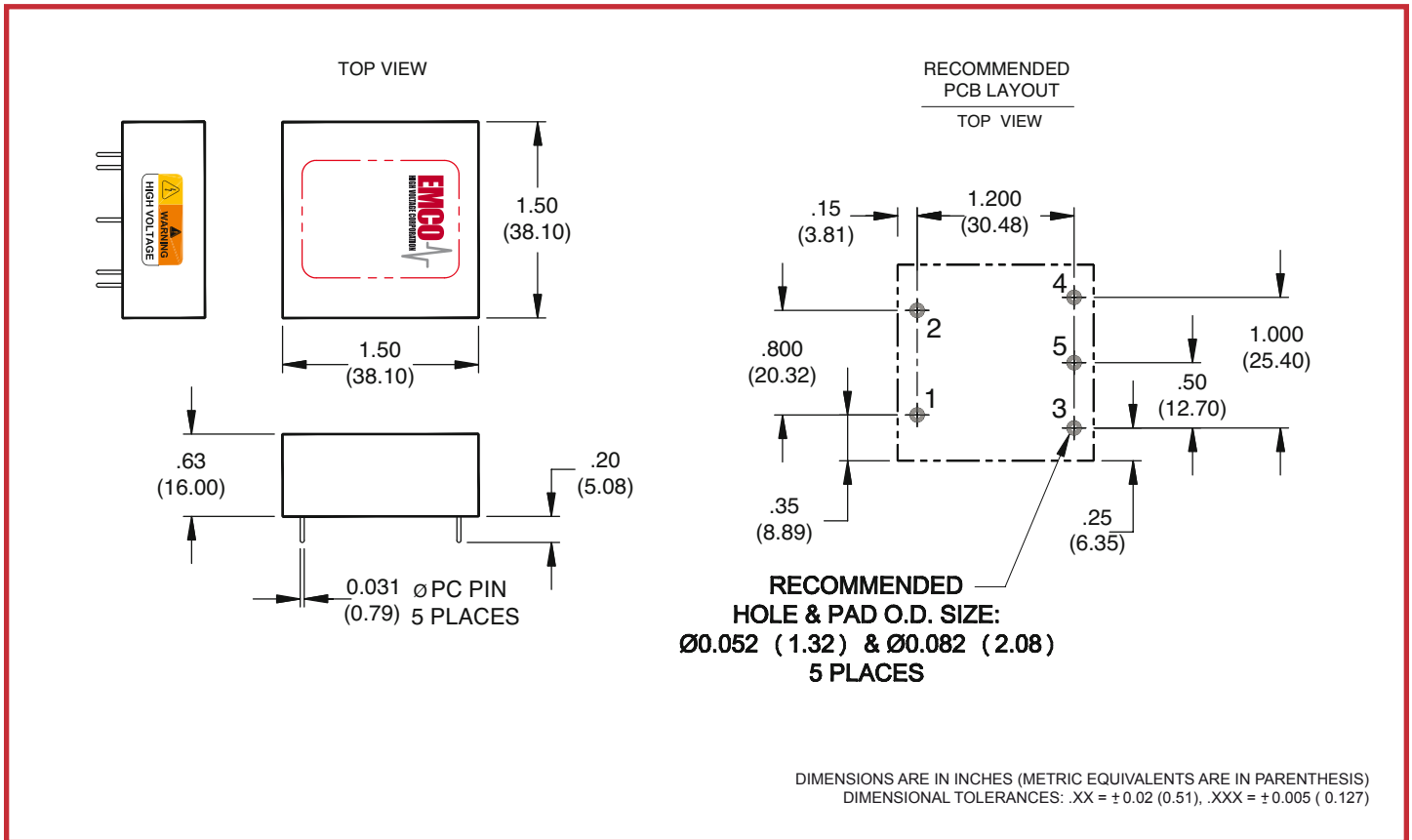

PARAMETER	VALUE
WEIGHT	Weight: 1.5 OZ (43 Grams)
VOLUME	1.4 cubic Inches (23 cubic centimeters)
DIMENSIONS	1.5L (38.1L) x 1.5W (38.1L) x 0.63H (16.0H)
CASE MATERIAL	Diallyl Phthalate (DAP)

PIN/WIRE #	FUNCTION
1	(+) Input
2	(-) Input
3	(+) Output
4	(-) Output

G25CT THRU G60CT MECHANICAL SPECIFICATIONS

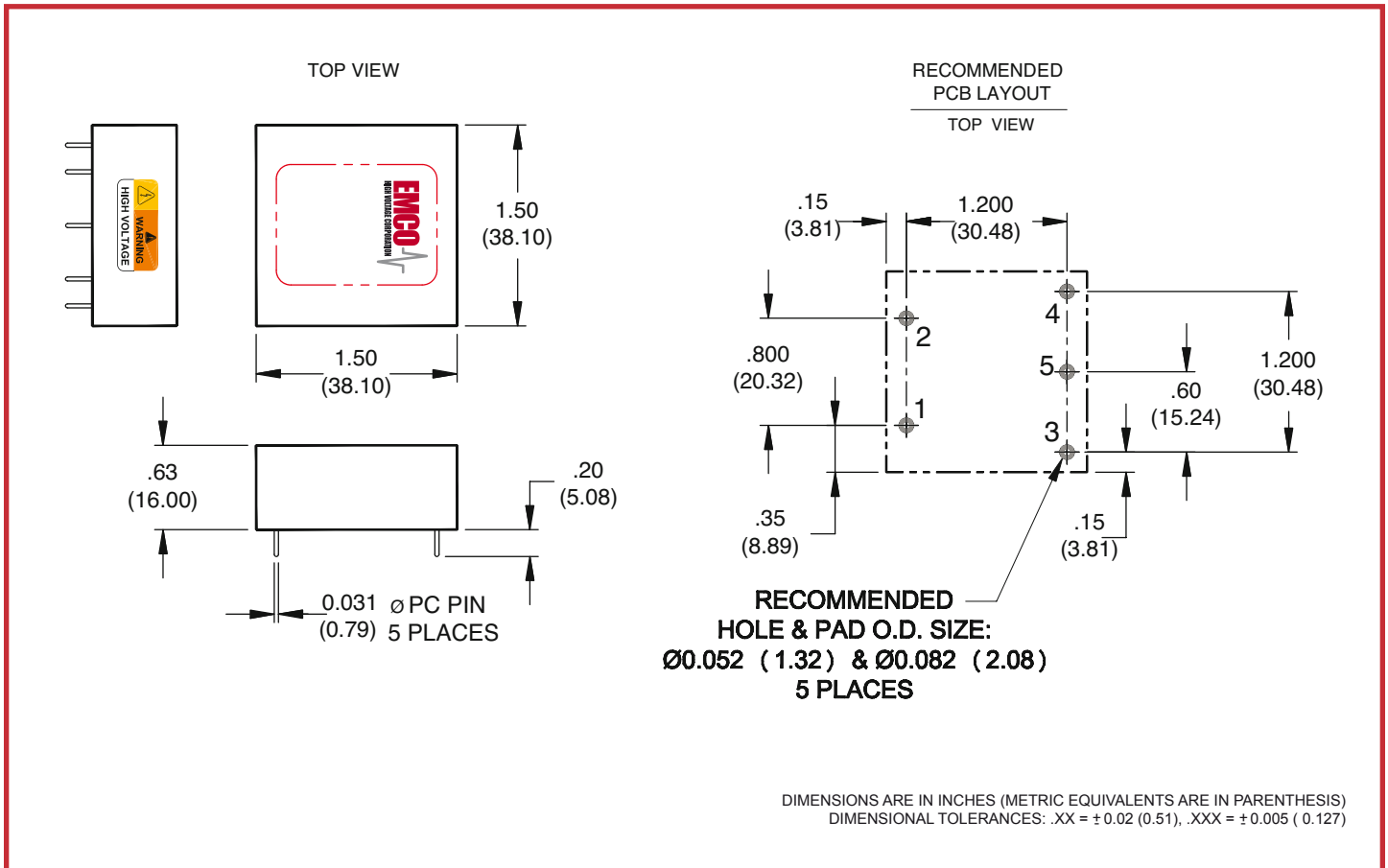

PARAMETER	VALUE
WEIGHT	Weight: 1.5 OZ (43 Grams)
VOLUME	1.4 cubic Inches (23 cubic centimeters)
DIMENSIONS	1.5L (38.1L) x 1.5W (38.1L) x 0.63H (16.0H)
CASE MATERIAL	Diallyl Phthalate (DAP)

PIN/WIRE #	FUNCTION
1	(+) Input
2	(-) Input
3	(+) Output
4	(-) Output

EXTERNAL EMI/RFI SHIELD

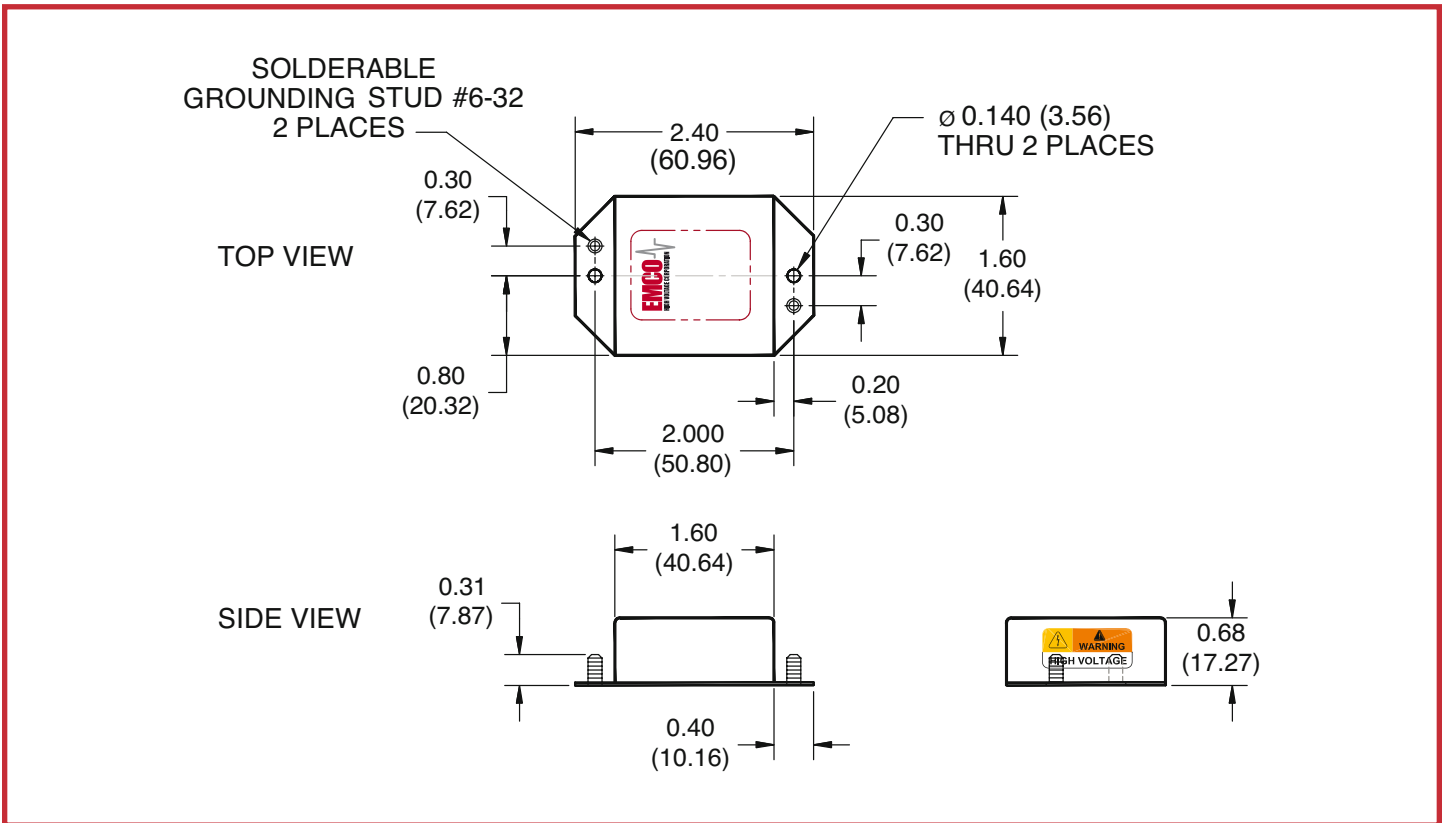

PARAMETER	VALUE
BOX SIZE	See Table
MATERIAL	0.03 (0.76mm) Aluminum
MOUNTING	Two Tabs With Thru-Holes

PARAMETER	VALUE
GROUND	Black Anodized Aluminum
DIMENSIONS WITH TAB	2.4L (60.96) x 1.6W (40.64) x 0.68H (17.27)
DIMENSIONS WITHOUT TAB	1.6L (40.64) x 1.6W (40.64) x 0.68H (17.27)

SHIELD DESCRIPTION

The "AB" Series provides low cost EMI/RFI shielding and rugged mounting for XP-EMCO High Voltage DC to DC converters. These five-sided aluminum enclosures feature a durable, non-conductive black anodized finish. The enclosures are manufactured at our own sheet metal fabrication facility, which allows for low cost and stock delivery. Add an "AB" suffix to the model number for a factory-installed enclosure (e.g. E10AB). Contact our sales department by phone, fax or email for immediate attention.

APPLICATION INFORMATION

These 5-sided aluminum enclosures feature a durable, non-conductive black anodized finish.

On models with outputs of 3kV or higher, special care must be taken to ensure adequate spacing and insulation between the metal can and the high voltage output. Single sided layout, encapsulants or conformal coating may be required.

Case grounding stud must be connected to ground. Case ground is not internally connected to (-) input.

APPLICATION NOTES

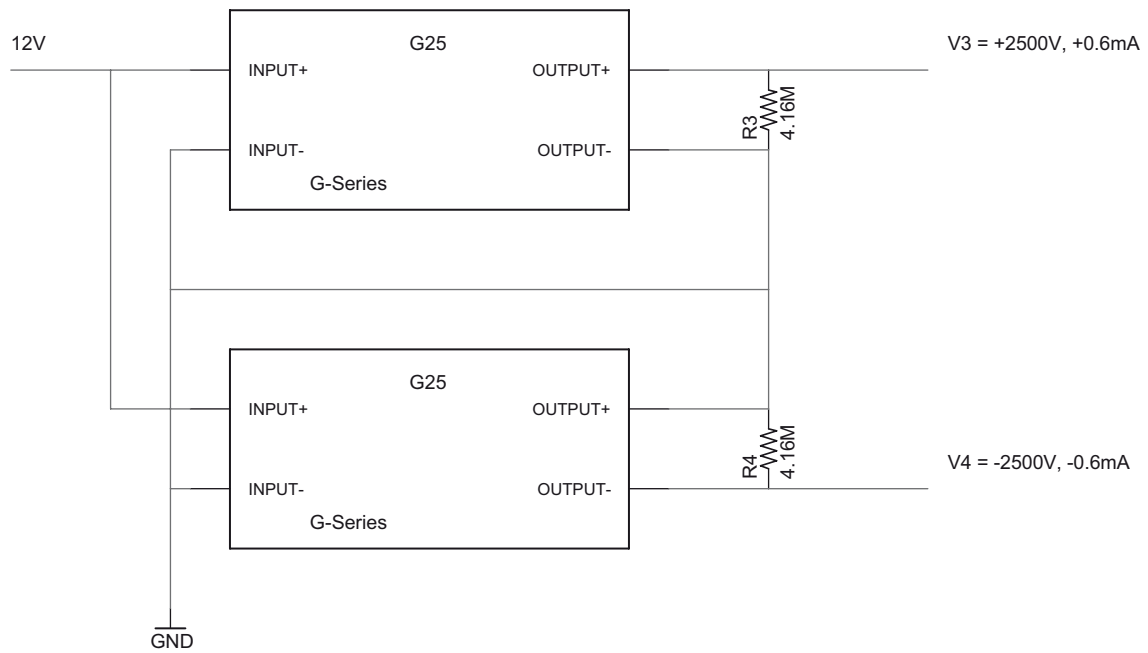
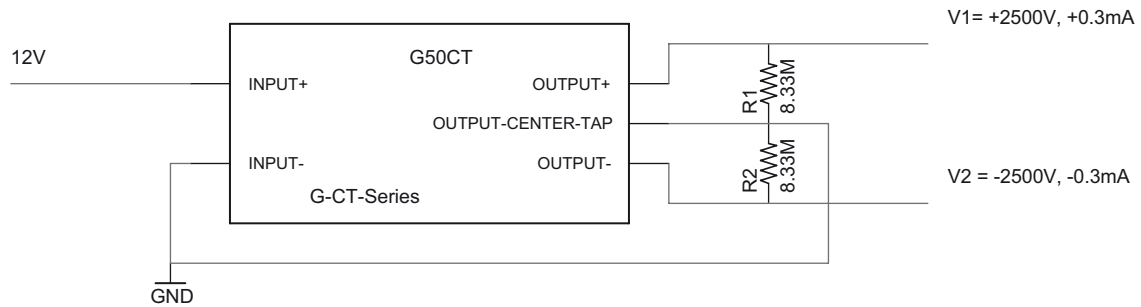

BLOCK DIAGRAM

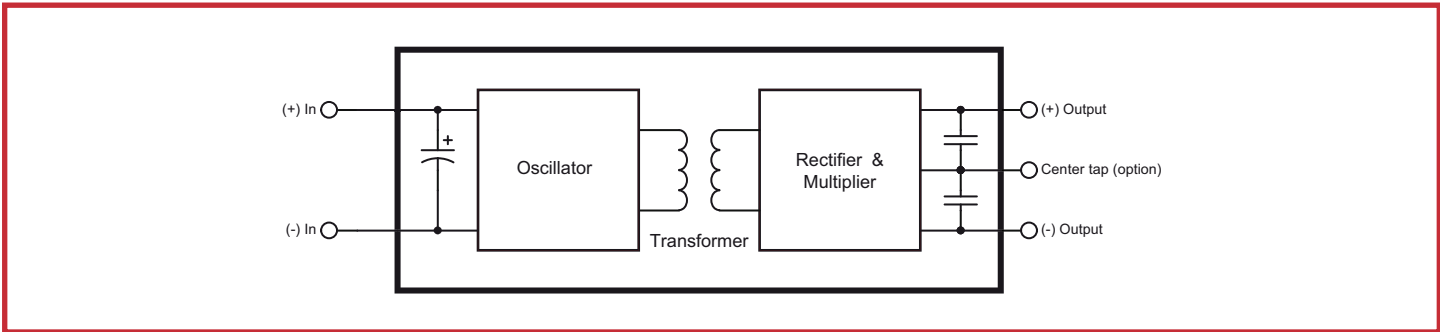

OPTION CODE TABLE

OPTION		ORDER CODE	MODELS
POLARITY	Positive / Negative reversible	Blank	ALL
	Bipolar center tap option	CT	ALL
OPTIONS	Shielding and Mounting Enclosure	AB	ALL

HOW TO ORDER

PART NUMBER SELECTOR:

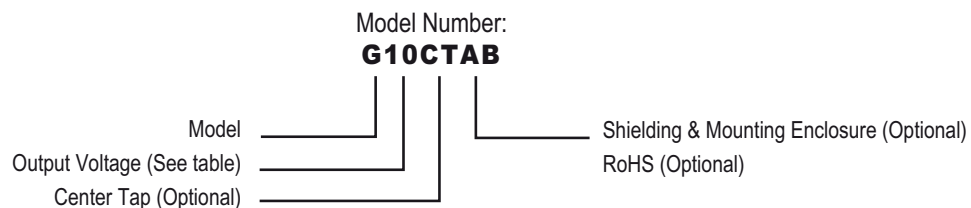

EXAMPLE: **G10CTRAB** (**G**-Model, **10**-Output Voltage, **CT**-Center Tap, **AB**-Shielding & Mounting Enclosure)

* Notes:

1. At maximum rated output voltage.
2. Output voltage is load dependent. Under light or no load conditions, reduce input voltage so maximum rated output voltage is not exceeded.
3. Specifications after 30 minute warm up, full load, at 25C unless otherwise indicated.
4. For center tap output units [CT option], the negative output voltage will be ~20% larger than the positive output voltage with respect to the center tap pin.
5. Ripple Specifications for center-tapped units applies to the voltage between the positive and negative output terminals.
6. Proper thermal management techniques are required to maintain safe case temperature at maximum power output.
7. The GPMT is only 0.4375W.
8. Models G40, G50 & G60 do not have internal bleeder resistors on the output. Provisions must be made externally to discharge the output capacitors.

XP-EMCO reserves the right to make changes on products and literature, including specifications, without notice. XP-EMCO standard product models are not recommended for "copy-exact" applications or any other application restricting product changes. "Copy-exact" options are available. Please contact an XP-EMCO sales representative for more details.