

**Proven  
Reliability**

# E SERIES

ISOLATED, PROPORTIONAL DC TO HV DC CONVERTERS

200V to 7kV at 3W / 8kV at 2W



## PRODUCT DESCRIPTION

The E Series is a broad line of small, versatile, component level building blocks in a PCB mount package that provide up to 7kV at 3 Watts continuous output power, (8kV at 2 Watts). This series features low ripple, noise, and EMI/RFI by utilizing a quasi-sinewave oscillator, excellent filtering techniques and a fully enclosed pot core transformer. The output voltage is directly proportional to the input voltage, and is linear from approximately 0.7 volts to maximum input. The isolated output allows for user selectable output polarity. Options include external aluminum box, and an output center tap which, when grounded, provides both positive and negative outputs from one low cost module.

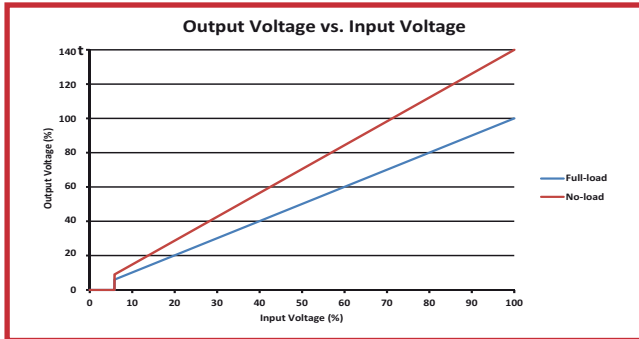

## APPLICATIONS

- Electrophoresis
- Capacitor Charging
- Field Generation
- Piezo Devices
- Mass Spectrometry
- Electrostatic Chuck
- Igniter / Spark Module
- Sustaining Ion Pumps

## OPTIONS

- Center Tap Models Available (CT Suffix)
- External EMI/RFI Shield (AB Suffix)
- Alternate Input/Output Combinations (Consult factory)
- Alternate Pin Patterns (Consult factory)

## PRODUCT SELECTION TABLE

MODEL	OUTPUT VOLTAGE*2	OUTPUT CURRENT*1
E02	200V	15mA
E02-5	250V	12mA
E03	300V	10mA
E05	500DV	6.0mA
E06	600V	5.0mA
E07-5	750V	4.0mA
E08	800V	3.7mA
E10	1kV	3.0mA
E12	1.2kV	2.5mA
E15	1.5kV	2.0mA
E20	2kV	1.5mA
E30	3kV	1.0mA
E40	4kV	0.75mA
E50	5kV	0.60mA
E60	6kV	0.50mA
E70 <sup>7</sup>	7kV	0.43mA
E80 <sup>7</sup>	8kV	0.25mA

## FEATURES

- Proportional Input/Output
- Compact, PCB Mount Package
- Low Ripple, Low EMI / RFI
- Proven Reliability
- Input/Output Isolation
- Low Leakage Current
- Low Input/Output Coupling Capacitance
- No External Components Required
- No Minimum Load Required
- MTBF: >2 Million Hours per Bellcore TR-332
- UL Certified Encapsulant, Meets 94V-0 Flammability
- Mounting Holes
- RoHS Compliant

ISO 9001:2008  
CERTIFIED

ISO 14001:2004  
CERTIFIED

RoHS  
COMPLIANT

IPC  
Certified J-STD-001  
Application Specialist



Distribution:

**hivolt.de**

hivolt.de GmbH & Co. KG  
Oehleckerring 40 • D-22419 Hamburg • Germany  
+49 40 537122-0  
info@hivolt.de • www.hivolt.de

47198H

PAGE 1

ELECTRICAL SPECIFICATIONS<sup>\*3</sup>

MODEL	INPUT VOLTAGE	OUTPUT CURRENT	RIPPLE <sup>*5</sup>	REVERSIBLE MODEL	OUTPUT VOLTAGE <sup>*2</sup>	CENTER TAP MODEL <sup>*4</sup>	OUTPUT VOLTAGE <sup>*2</sup>
E02/E02CT	0 to 12V	15mA	<0.25%	E02	0 to 200V	E02CT	0 to +/- 100V
E02-5/E02-5CT	0 to 12V	12mA	<0.75%	E02-5	0 to 250V	E02-5CT	0 to +/- 125V
E03/E03CT	0 to 12V	10mA	<1%	E03	0 to 300V	E03CT	0 to +/- 150V
E05/E05CT	0 to 12V	6.0mA	<0.1%	E05	0 to 500V	E05CT	0 to +/- 250V
E06/E06CT	0 to 12V	5.0mA	<0.1%	E06	0 to 600V	E06CT	0 to +/- 300V
E07-5/E07-5CT	0 to 12V	4.0mA	<0.1%	E07-5	0 to 750V	E07-5CT	0 to +/- 375V
E08/E08CT	0 to 12V	3.7mA	<0.1%	E08	0 to 800V	E08CT	0 to +/- 400V
E10/E10CT	0 to 12V	3.0mA	<0.05%	E10	0 to 1kV	E10CT	0 to +/- 500V
E12/E12CT	0 to 12V	2.5mA	<0.05%	E12	0 to 1.2kV	E12CT	0 to +/- 600V
E15/E15CT	0 to 12V	2.0mA	<0.05%	E15	0 to 1.5kV	E15CT	0 to +/- 750V
E20/E20CT	0 to 12V	1.5mA	<0.25%	E20	0 to 2kV	E20CT	0 to +/- 1kV
E30/E30CT	0 to 15V	1.0mA	<0.25%	E30	0 to 3kV	E30CT	0 to +/- 1.5kV
E40/E40CT	0 to 15V	0.75mA	<0.5%	E40	0 to 4kV	E40CT	0 to +/- 2kV
E50/E50CT	0 to 15V	0.60mA	<0.5%	E50	0 to 5kV	E50CT	0 to +/- 2.5kV
E60/E60CT	0 to 15V	0.50mA	<0.5%	E60	0 to 6kV	E60CT	0 to +/- 3kV
E70/E70CT	0 to 15V	0.43mA	<1%	E70	0 to 7kV	E70CT	0 to +/- 3.5kV
E80/E80CT	0 to 15V	0.25mA	<1.25%	E80	0 to 8kV	E80CT	0 to +/- 4kV

ELECTRICAL SPECIFICATIONS<sup>\*3</sup>

PARAMETER	VALUE
INPUT VOLTAGE	0 to 12V (E02 to E20)
	0 to 15V (E30 to E80)
TURN-ON VOLTAGE	<0.7V
INPUT CURRENT	<175mA, NO LOAD
	<400mA, FULL LOAD
ISOLATION	< +/-3.5kV BIAS (E02 TO E60)
	< +/-500V BIAS (E70 TO E80)
INPUT CAPACITANCE	66uF (E02 to E60)
	240uF (E70 to E80)
RESPONSE TIME	<10mS (Typical)
OUTPUT VOLTAGE TOLERANCE	+/-5% (Full Load, 100% output voltage)
FREQUENCY	30 to 100KHz
OPERATING TEMPERATURE <sup>5</sup>	-10C to +60°C Case (E02 TO E60)
	-10C to +50°C Case (E70 TO E80)
STORAGE TEMPERATURE	-25C to +90°C

E02-E60 MECHANICAL SPECIFICATIONS\*2

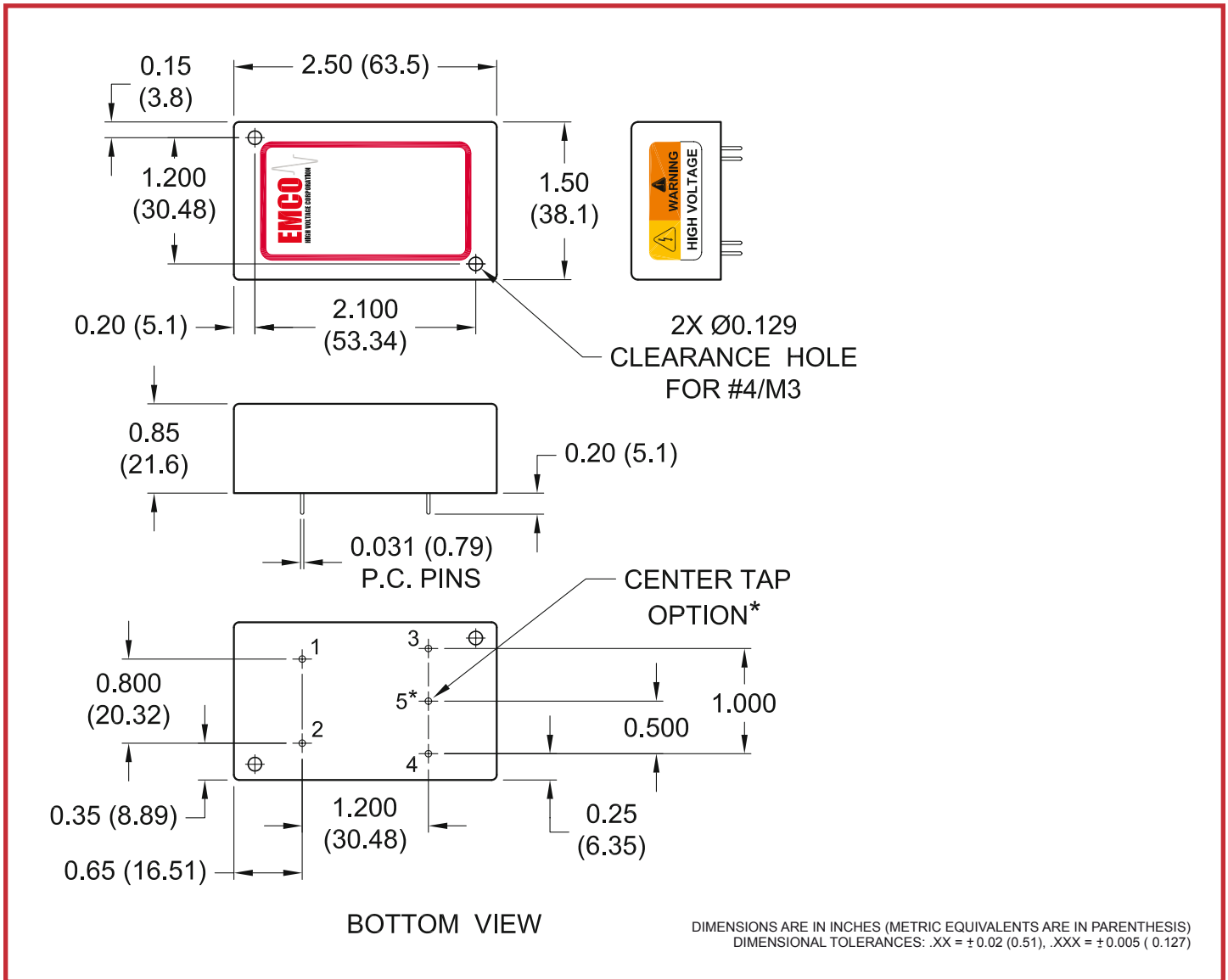

PARAMETER	VALUE
WEIGHT	3 OZ (85.05 Grams)
VOLUME	<3.2 cubic Inches (52.2 cubic centimeters)
DIMENSIONS	2.5L (63.5L) x 1.5W (38.1W) x 0.85H (21.6H)
CASE MATERIAL	Diallyl Phthalate (DAP)

PIN #	FUNCTION
1	(+) Input
2	(-) Input
3	(+) Output
4	(-) Output
5	Center tap (optional)

E02-E60 "B" PATTERN MECHANICAL SPECIFICATIONS\*2

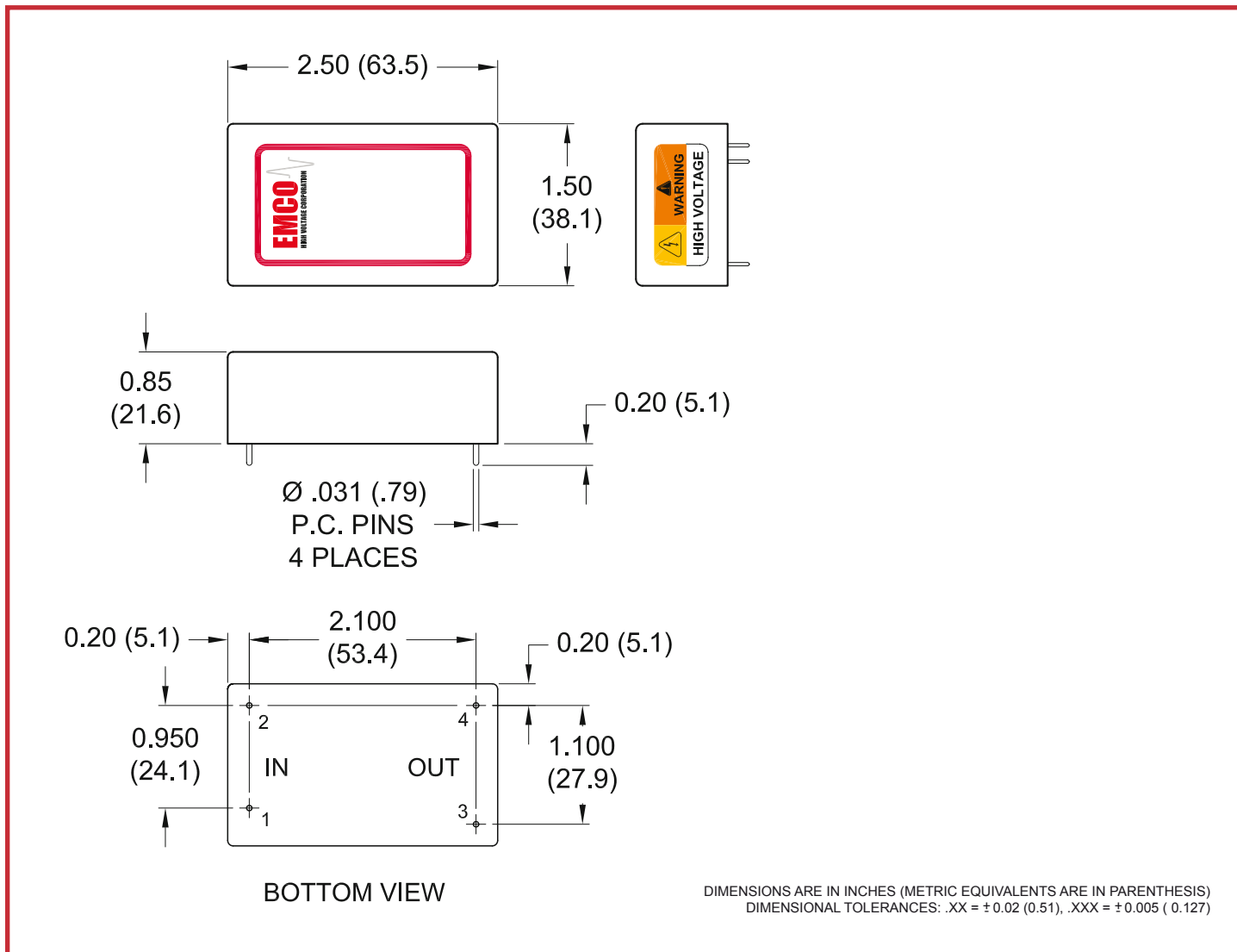

PARAMETER	VALUE
WEIGHT	3 OZ (85.05 Grams)
VOLUME	<3.2 cubic Inches (52.2 cubic centimeters)
DIMENSIONS	2.5L (63.5L) x 1.5W (38.1W) x 0.85H (21.6H)
CASE MATERIAL	Diallyl Phthalate (DAP)

PIN #	FUNCTION
1	(+) Input
2	(-) Input
3	(+) Output
4	(-) Output

E70-E80 MECHANICAL SPECIFICATIONS\*2

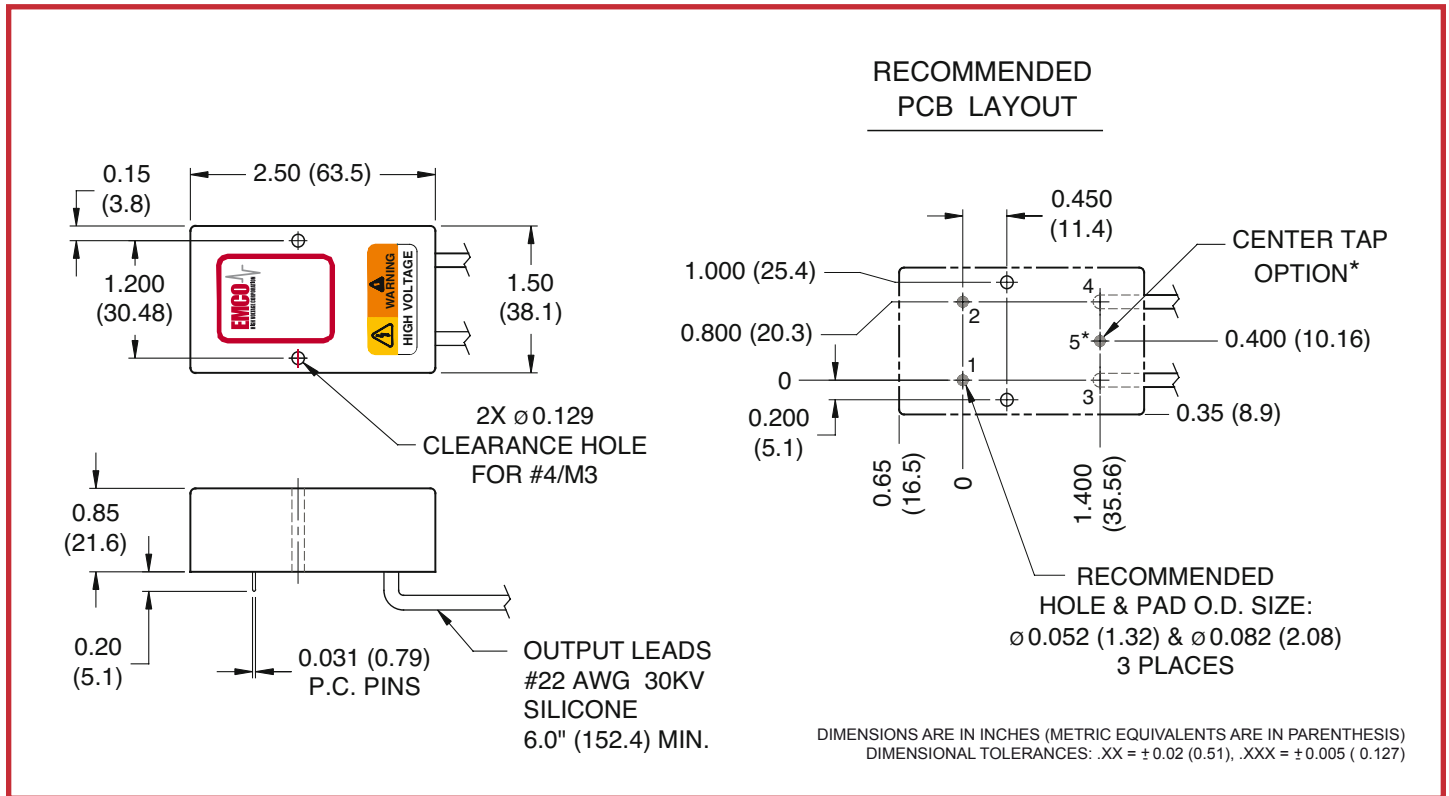

PARAMETER	VALUE
WEIGHT	3 OZ (85.05 Grams)
VOLUME	<3.2 cubic Inches (52.2 cubic centimeters)
DIMENSIONS	2.5L (63.5L) x 1.5W (38.1W) x 0.85H (21.59H)
CASE MATERIAL	Diallyl Phthalate (DAP)

PIN/WIRE #	FUNCTION
1	(+) Input
2	(-) Input
3	(+) Output
4	(-) Output
5	Center tap (optional)

EXTERNAL EMI/RFI SHIELD

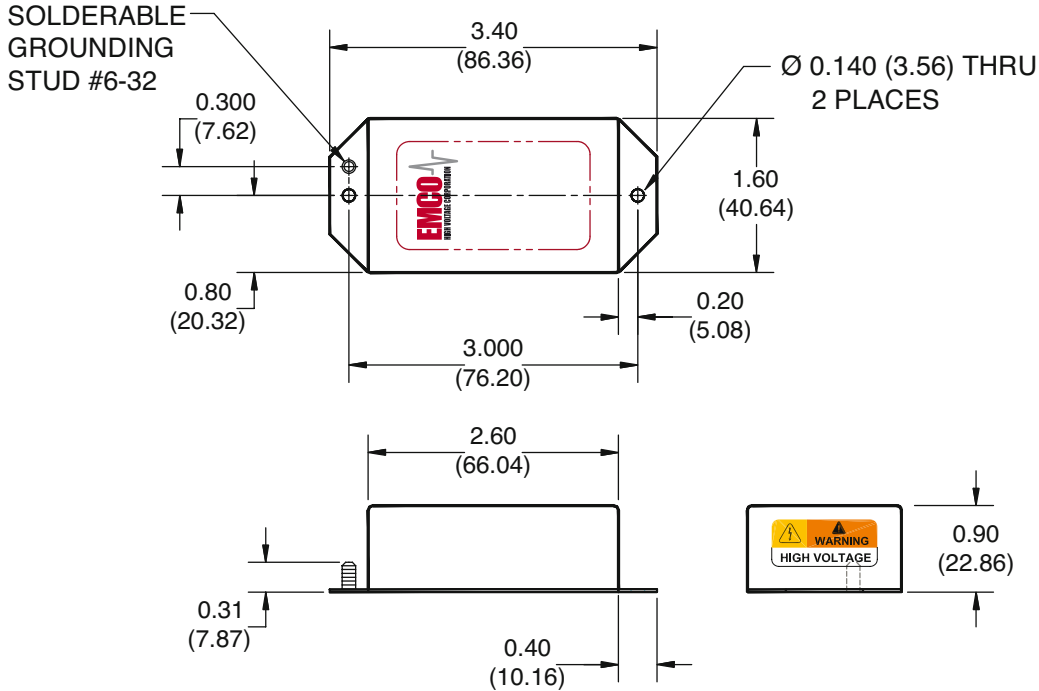

DIMENSIONS ARE IN INCHES (METRIC EQUIVALENTS ARE IN PARENTHESIS)  
 DIMENSIONAL TOLERANCES: .XX = ±0.02 (0.51), .XXX = ±0.005 (0.127)

PARAMETER	VALUE
BOX SIZE	See table
MATERIAL	0.03 (0.76mm) Aluminum
FINISH	Black Anodize
MOUNTING	Two Tabs With Thru-Holes

PARAMETER	VALUE
GROUND	Black Anodized Aluminum
DIMENSIONS WITH TAB	3.4L (86.36L) x 1.6W (40.64W) x 0.9H (22.86H)
DIMENSIONS WITHOUT TAB	2.6L (66.04L) x 1.6W (40.64W) x 0.9H (22.86H)

SHIELD DESCRIPTION

The "AB" Series provides low cost EMI/RFI shielding and rugged mounting for XP-EMCO High Voltage DC to DC converters. These five-sided aluminum enclosures feature a durable, non-conductive black anodized finish. The enclosures are manufactured at our own sheet metal fabrication facility, which allows for low cost and stock delivery. Add an "AB" suffix to the model number for a factory-installed enclosure (e.g. E10AB). Contact our sales department by phone, fax or email for immediate attention.

APPLICATION INFORMATION

These 5-sided aluminum enclosures feature a durable, non-conductive black anodized finish.

On models with outputs of 3kV or higher, special care must be taken to ensure adequate spacing and insulation between the metal can and the high voltage output. Single sided layout, encapsulants or conformal coating may be required.

Case grounding stud must be connected to ground. Case ground is not internally connected to (-) input.



Distribution:  
**hivolt.de**

hivolt.de GmbH & Co. KG  
 Oehleckerring 40 • D-22419 Hamburg • Germany  
 +49 40 537122-0  
 info@hivolt.de • www.hivolt.de

**BLOCK DIAGRAM**

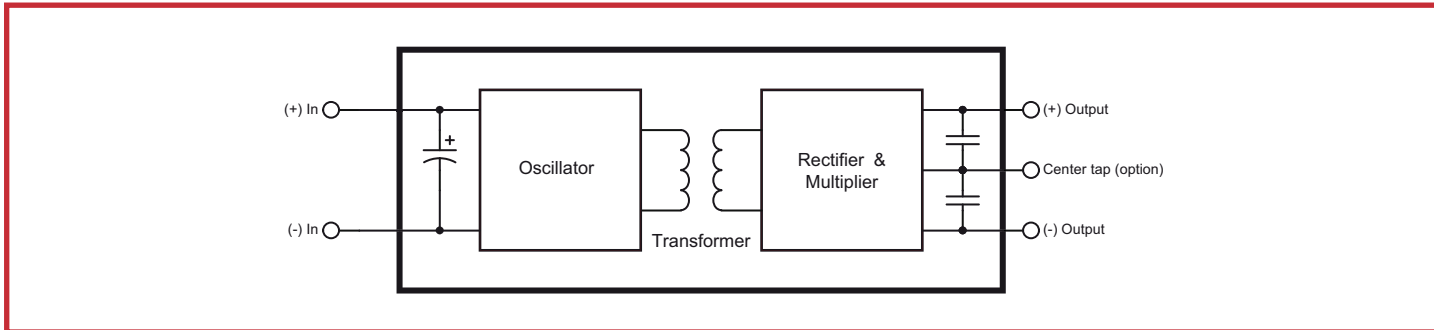

**OPTION CODE TABLE**

OPTION		ORDER CODE	MODELS
POLARITY	Positive / Negative reversible	Blank	ALL
	Bipolar center tap option	CT	ALL
OPTIONS	Shielding and Mounting Enclosure	AB	ALL

**HOW TO ORDER**

**PART NUMBER SELECTOR:**

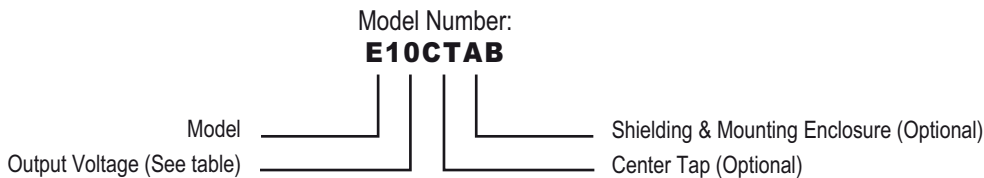

EXAMPLE:

**E10CTAB** (E-Model, 10-Output Voltage, CT-Center Tap, AB-Shielding & Mounting Enclosure)

\* Notes:

1. At maximum rated output voltage.
2. Output voltage is load dependent. Under light or no load conditions, reduce input voltage so maximum rated output voltage is not exceeded.
3. Specifications after 30 minute warm up, full load, at 25C unless otherwise indicated.
4. For center tap output units [CT option], the negative output voltage will be ~10% larger than the positive output voltage with respect to the center tap pin.
5. Ripple Specifications for center-tapped units applies to the voltage between the positive and negative output terminals.
6. Proper thermal management techniques are required to maintain safe case temperature at maximum power output.
7. This unit has flying leads on the output and clearance holes for mounting.

EMCO reserves the right to make changes on products and literature, including specifications, without notice. EMCO standard product models are not recommended for "copy-exact" applications or any other application restricting product changes. "Copy-exact" options are available. Please contact an EMCO sales representative for more details.