

## 25 - 100V, 1W ULTRA-THIN, MINIATURE, DC TO DC CONVERTER

**EMCO** HIGH VOLTAGE CORPORATION

- Low Ripple
- Well Regulated
- High Stability
- Analog Programmable
- Ultra-Thin, 0.16 inches (4mm) thick
- Compact SIP Package
- Designed for High Quantity Applications
- High Performance / Low Cost

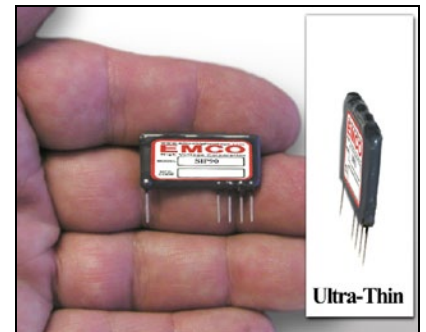

### • APPLICATIONS

- APD biasing

Ideal for APD biasing, and MEMS driver applications, the SIP Series provides high performance in an ultra-thin, miniature single in-line package. Designed for low cost, high quantity applications, these DC to DC converters deliver high stability with very low ripple. The output voltage is programmable via a 0 to 5 volt analog voltage, such as the output from a DAC. This allows the user to temperature compensate the APD bias voltage with hardware or software solutions.

The output voltage is inversely related to the programming voltage, i.e. 5V applied to the programming input programs the output voltage to the minimum level. Conversely, 0 volts on the programming input sets the output voltage to the maximum level. The supply is linearly programmable through this range<sup>\*2</sup>. An enable/disable function is included. TTL Low (open collector compatible) disables the output voltage to less than 10 volts.

MODEL	OUTPUT VOLTAGE	OUTPUT <sup>*2</sup> CURRENT	SUPPLY <sup>*2</sup> VOLTAGE	INPUT CURRENT	RIPPLE <sup>*1</sup>	REGULATION <sup>*1</sup>		CASE
						Line	Load	
SIP90	<25V to 90V	0mA to 1mA	3V to 6.7V	<150mA	<5mV	<0.06%	<0.025%	A
SIP100	<35V to 100V	0mA to 10mA	4V to 6.7V	<350mA	<10mV	<0.2%	<0.1%	B

### • SPECIFICATIONS

- Operating Temp: -20°C to +70°C  
 Storage Temp: -20°C to +105°C  
 Stability: <0.01%/hr/8hrs after 1hr warm up<sup>\*1</sup>  
 Temperature Coefficient: <200ppm/°C<sup>\*1</sup>  
 Programming Voltage: 5V max.

\*Operating Condition: see next page

\*Application Notes: see next page

Specifications are subject to change without notice.

Ultra-Thin!



Pin #	Function
1	Programming input
2	Ground
3	Disable: TTL low, open collector compatible
4	Supply voltage
5	Output voltage

### • DIMENSIONS

- Size Case A: 1.15 x 0.55 x 0.16 inch<sup>3</sup>  
 (29.2 x 13.97 x 4.06 mm<sup>3</sup>)  
 Case B: 1.45 x 0.75 x 0.16 inch<sup>3</sup>  
 (36.83 x 19.05 x 4.06 mm<sup>3</sup>)  
 Weight Case A: <0.2oz (5 grams)  
 Case B: <0.25oz (7.1 grams)  
 Packaging: Epoxy Coated

#### Case A

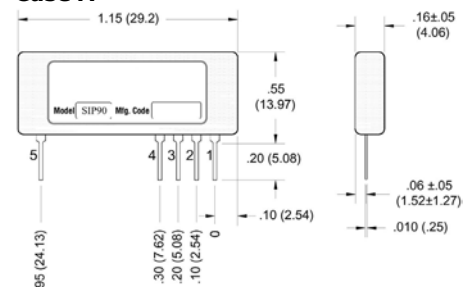

#### Case B

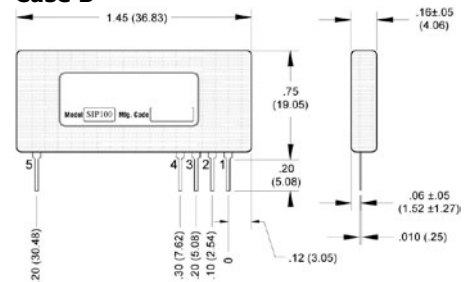

Dimensions are in Inches  
 Dimensional Tolerances: ±0.03 (.76mm)  
 (Metric equivalents in parenthesis)

**\*1 Operating Condition:**

Typical operation: 5V in, full output voltage and load, +25°C

**\*2 Application Notes:**

$$\text{SIP90 Programming Voltage} \cong \frac{90.5 - V_{out}}{14.1}$$

$$\text{SIP100 Programming Voltage} \cong \frac{100 - V_{out}}{15.8}$$

**Ripple Measurements:**

1. Ripple specified at maximum output power.
2. Set scope bandwidth limit to 20MHz.

**Programming pin(#1):**

1. Pin should not be left open for min Vout.
2. Pin must be grounded for max Vout.
3. Pin can be modeled in the following way:

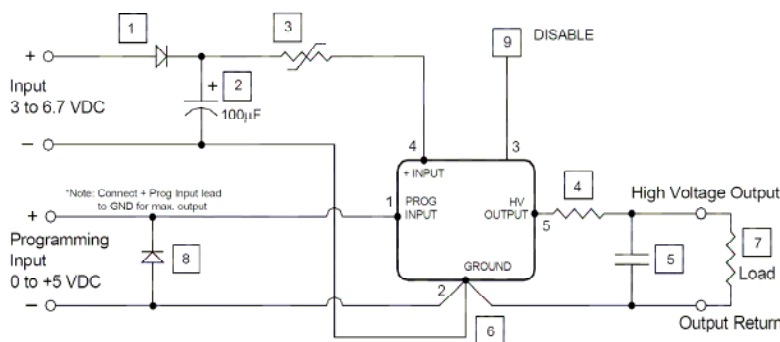

1. Diode provides reverse polarity protection.
2. Capacitor reduces ripple.
3. Resettable fuse provides indefinite short circuit protection.
4. Series resistance increases arc protection and reduces ripple (when used with an output capacitor).
5. Capacitor reduces ripple.
6. IMPORTANT: Keep Input, Programming and Output return paths separate to eliminate ground loop accuracy errors.
7. Conformal coating recommended on all exposed high voltage conductors.
8. Diode provides protection against negative programming voltage or negative transient spike.
9. DISABLE: TTL low open collector compatible.  
ON/OFF CONTROL: ON = 5 Volts or N.C.  
OFF = 0 Volts

**OUTPUT VOLTAGE (Vout) vs. PROGRAMING VOLTAGE (PV)**

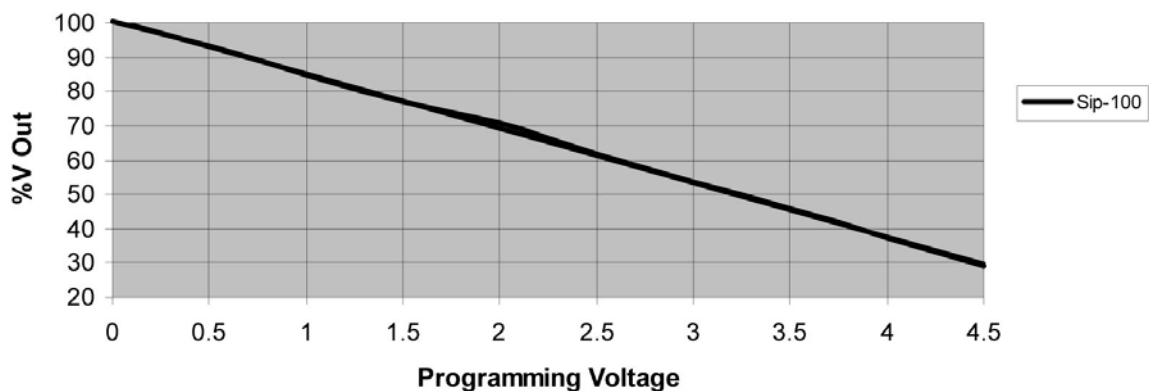

**• OPTIONS**

- R RoHS Compliant